



# MANUAL SEALING TONGS

## 1S T-SERIES

These portable welding tongs with generator can be used to close airtight bags, and also to make containment locks from flat film, to prevent the spread of radioactive contamination during dismantling and maintenance operations... The 2 thermocouples ensure permanent and continuous monitoring of the welding zone, and therefore hermetic sealing to prevent any leakage or contamination during transport and storage.



1S en T

THEY TRUST US



### Uses



Nuclear sector



Laboratory pharmaceutical and biological



- ✓ T-shape for easy assembly of flat pieces of film to make airlocks and guarantee a perfect seal.
- ✓ Control and regulation of the welding temperature of each heating tapes by a system of 2 thermocouples associated with an electronic board.
- ✓ Continuous monitoring of welding parameters defined during the qualification process.
- ✓ Quality and regularity of welds: traceability by memorising welding cycles.
- ✓ Easy to use: all welding steps are submitted to the operator for approval.
- ✓ Multifunction parameter-setting software (time, temperature, pressure...).



**1 year warranty<sup>(1)</sup>**

<sup>(1)</sup>Except wear parts



Compliance with CE standards

## TECHNICAL DATA

MODELS						
<b>1S 102T</b>	15 x 35 x 18 cm	100 x 12 mm	manual	2 kg	4,5 m	380 W
<b>1S 202T</b>	25 x 35 x 18 cm	200 x 12 mm		2,2 kg		
<b>1S 258T</b>	30 x 35 x 18 cm	250 x 8 mm		2,3 kg		
<b>1S 252T</b>	30 x 35 x 18 cm	250 x 12 mm		2,3 kg		
<b>1S 302T</b>	35 x 35 x 18 cm	300 x 12 mm		2,5 kg		
<b>1S 404T</b>	45 x 35 x 18 cm	400 x 4 mm		2,7 kg		

## GENERATOR

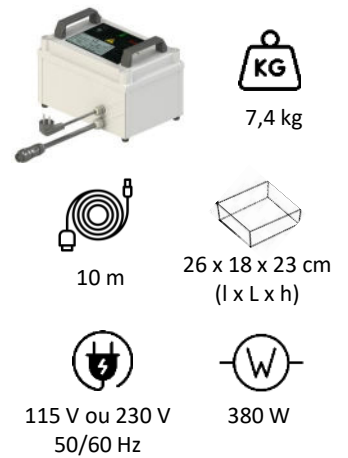

## EQUIPMENT

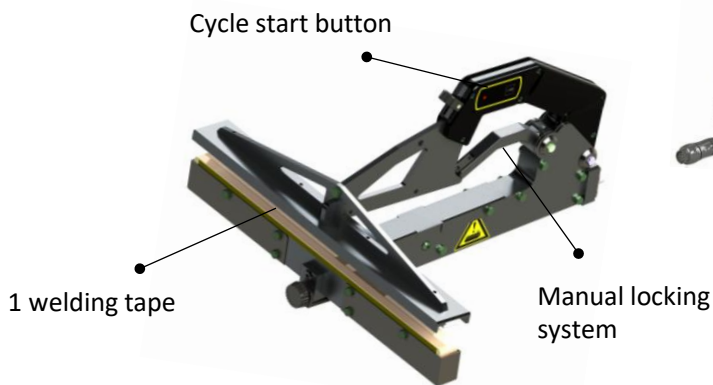

Generator with display control panel

## CONFIGURATION SOFTWARE

- ✓ 2 secure profiles with different user rights.
- ✓ History and traceability by memorising welding cycles.
- ✓ Integration of weld characteristics according to needed parameters: material, thickness...

(more information on page 3)



## ZOOM CONTROL PANEL

- 1 to 9 adaptable programs in memory.
- Simple 4-digit messages describing the procedure at each step of the process.



## TABLE OPTION

Compact work table with 5 wheels swivelling at 360° with brakes.

Not height-adjustable.

(more information in the tables product leaflet).

ref. DESSCHAR



## Need more information?

Contact the sales department



+33 (0)4 74 00 59 54



## ZOOM CONFIGURATION SOFTWARE

MANUAL  
SEALING TONGS  
1S T-SERIES

### THE SOFTWARE SUPPLIED WITH THE TONG ENABLES :

- Loading welding parameters.
- A record of the history of welds made with the tong.
- Diagnosis of incidents that may have blocked the welding process.
- The cycle is stopped if one of the parameters differs from that defined during the qualification process: the tong is held in the closed position to ensure that containment is maintained.  
(A warning message appears on the display).



### PARAMETERS :

The *parameters* menu gives all the information relating to the tong, in particular the tong serial number, the cycle counters (total and partial)... and allows the welding parameters to be defined according to the type of film.

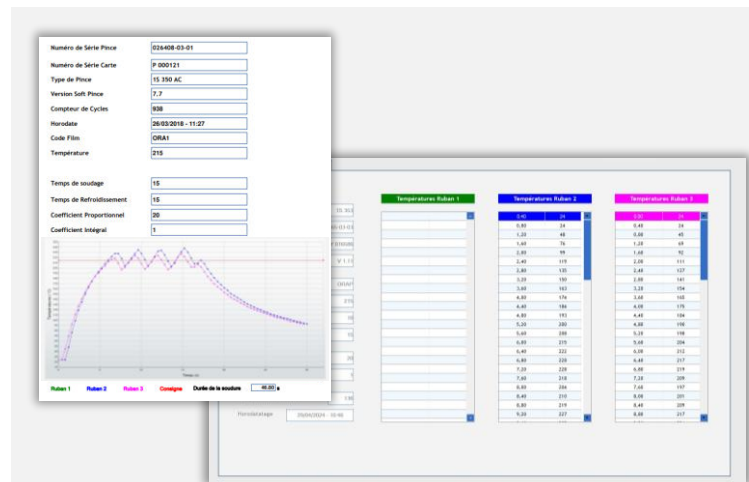
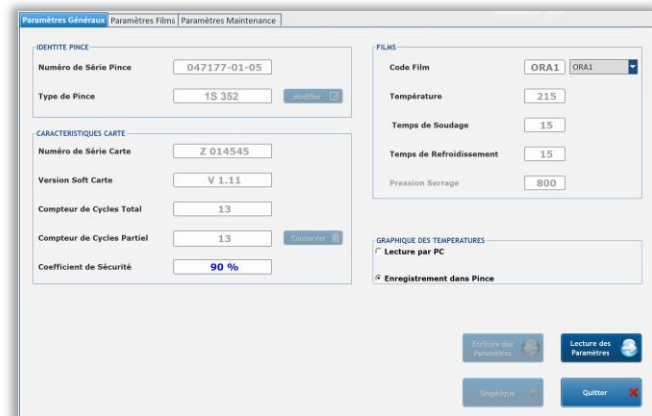

For each weld recorded in the history, the software provides details of the temperatures recorded every 300 milliseconds by each thermocouple.

### HISTORY OF WELDING CYCLES AND DEFECTS :

The software allows you to view the last 100 welding cycles with the exact temperature of each welding wire (stored in graphical and tabular form), as well as all the following information:

- Date and time of welding
- Film code
- Pressure
- Welding duration
- Cooling duration
- Counter

Date	Heure	Compteur	Type Pince	Code Film	Température	Pression Serrage	Tps Soudage	Tps Refroidis.
29/04/2024	09:54	130	1S 353	ORAP	215	0	10	15
29/04/2024	09:56	131	1S 353	ORAP	215	0	10	15
29/04/2024	09:58	132	1S 353	ORAP	215	0	10	15
29/04/2024	10:02	133	1S 353	ORAP	215	0	10	15
29/04/2024	10:05	134	1S 353	ORAP	215	0	10	15
29/04/2024	10:40	135	1S 353	ORAP	215	0	10	15
29/04/2024	10:46	136	1S 353	ORAP	215	0	10	15
29/04/2024	10:52	130	1S 353	ORAP	215	0	10	15
29/04/2024	10:54	131	1S 353	ORAP	215	0	10	15
29/04/2024	10:59	132	1S 353	ORAP	215	0	10	15
29/04/2024	11:03	133	1S 353	ORAP	215	0	10	15
29/04/2024	16:48	134	1S 353	ORAP	215	0	10	15
29/04/2024	16:51	135	1S 353	ORAP	215	0	10	15
29/04/2024	17:00	136	1S 353	ORAP	215	0	10	15
29/04/2024	17:01	137	1S 353	ORAP	215	0	10	15

Need more information?



Contact the sales department: +33 (0)4 74 00 59 54